



ECOFIVE

(Eco-friendly fishing vessel)

1. Lower environmental footprint
 2. Higher seafood quality
 3. Increased safety
 4. Better economy
 5. Greater social impact
- More sustainable fisheries



New trawl handling system

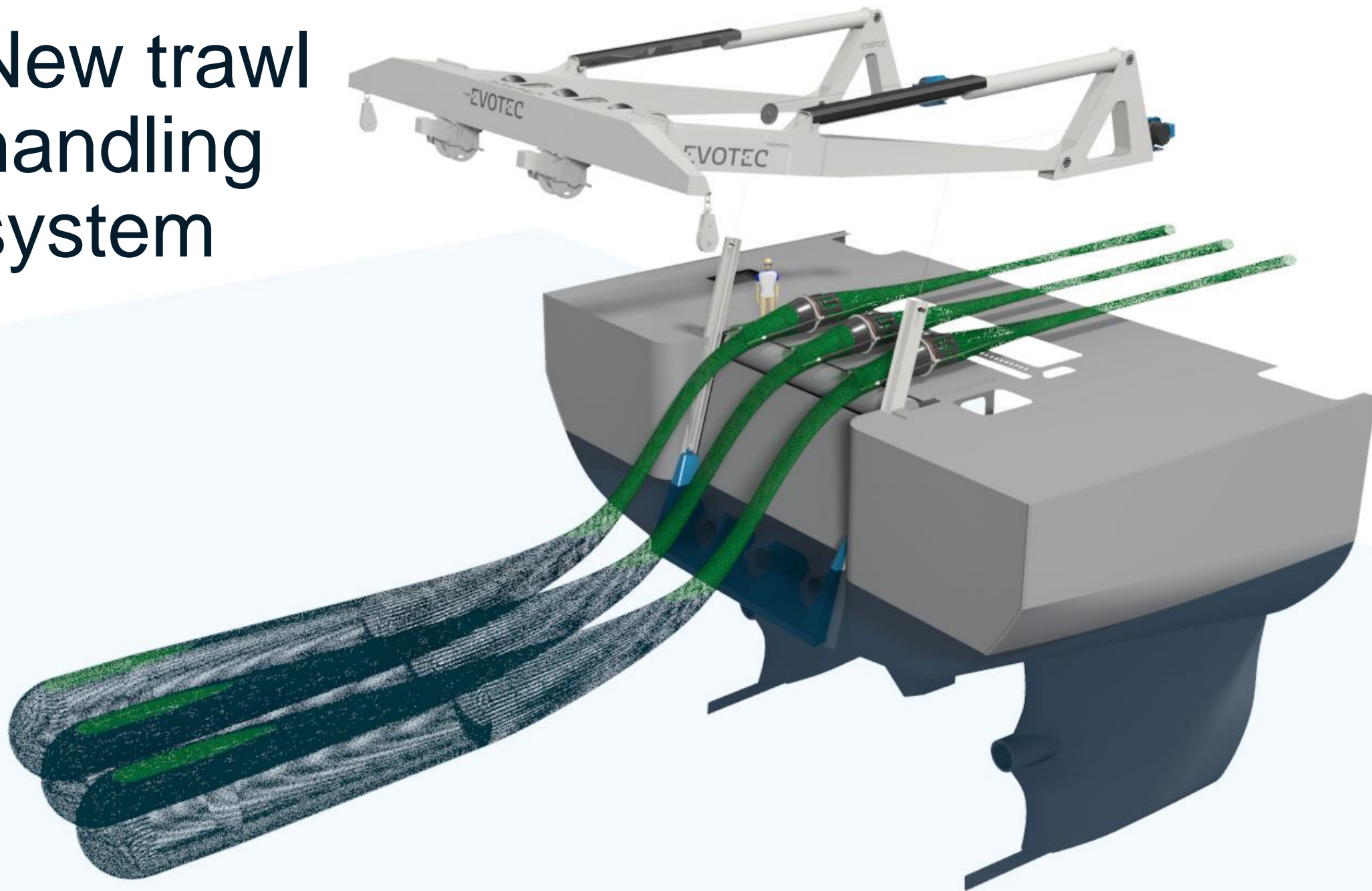

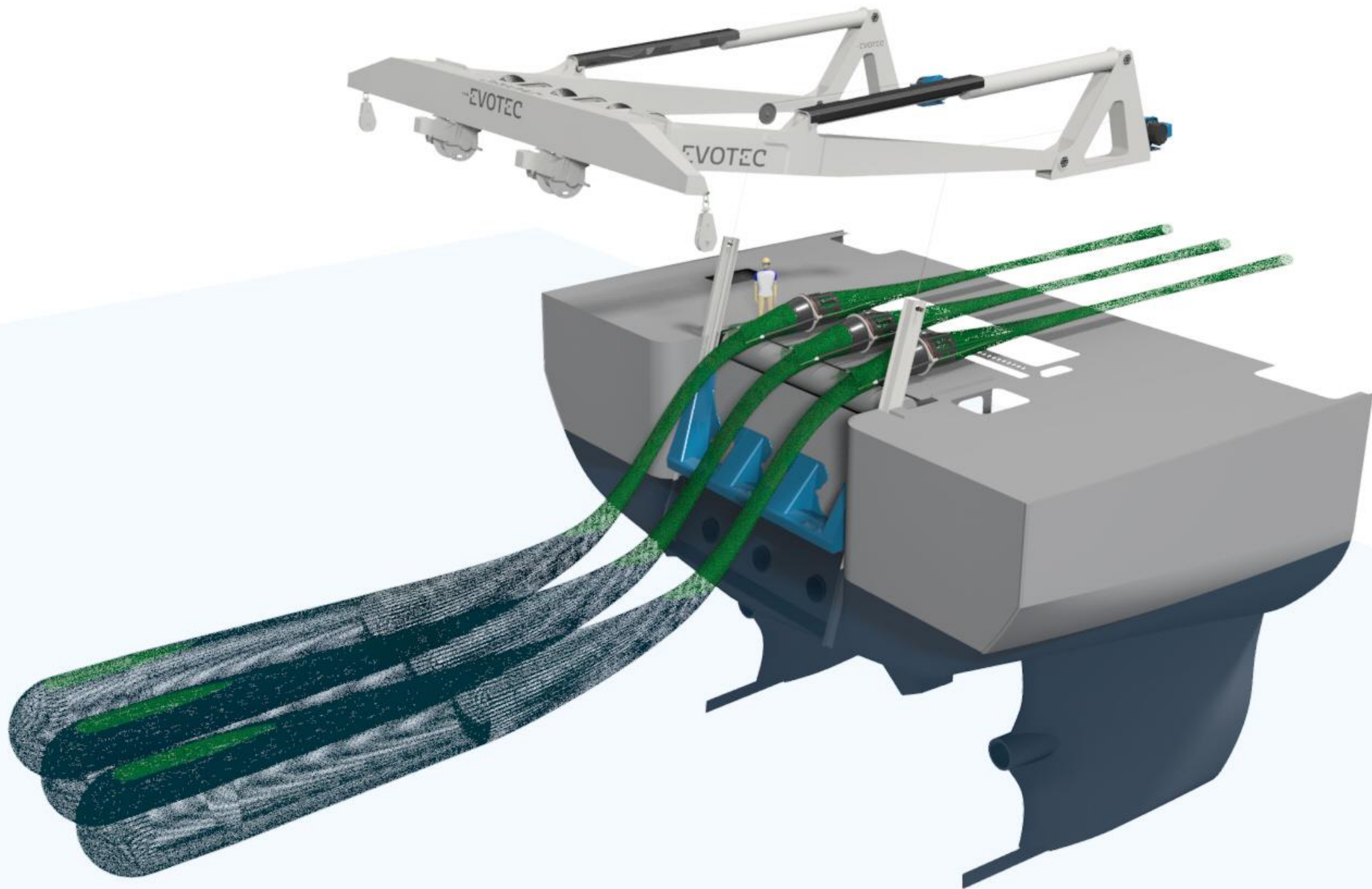

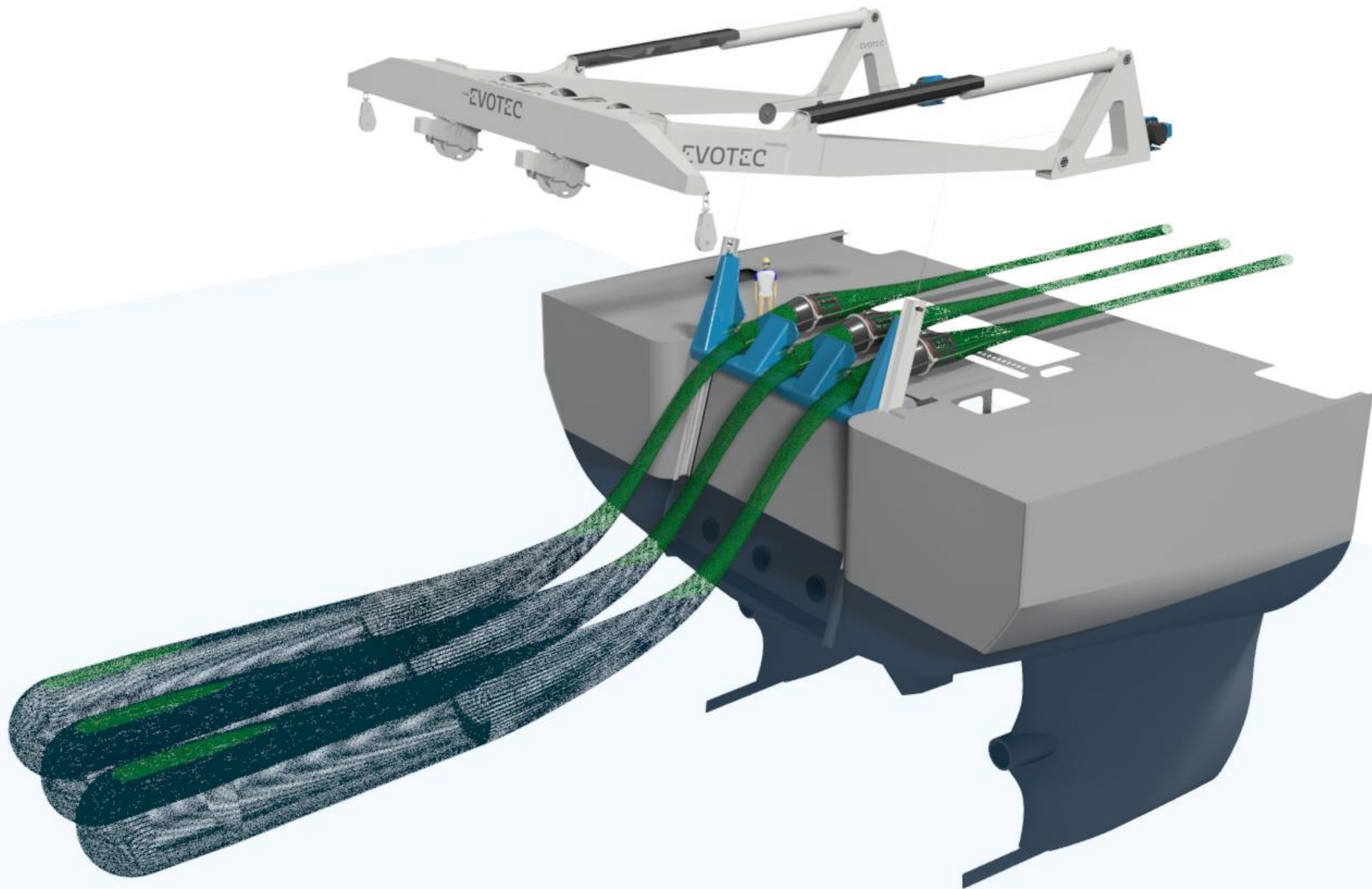

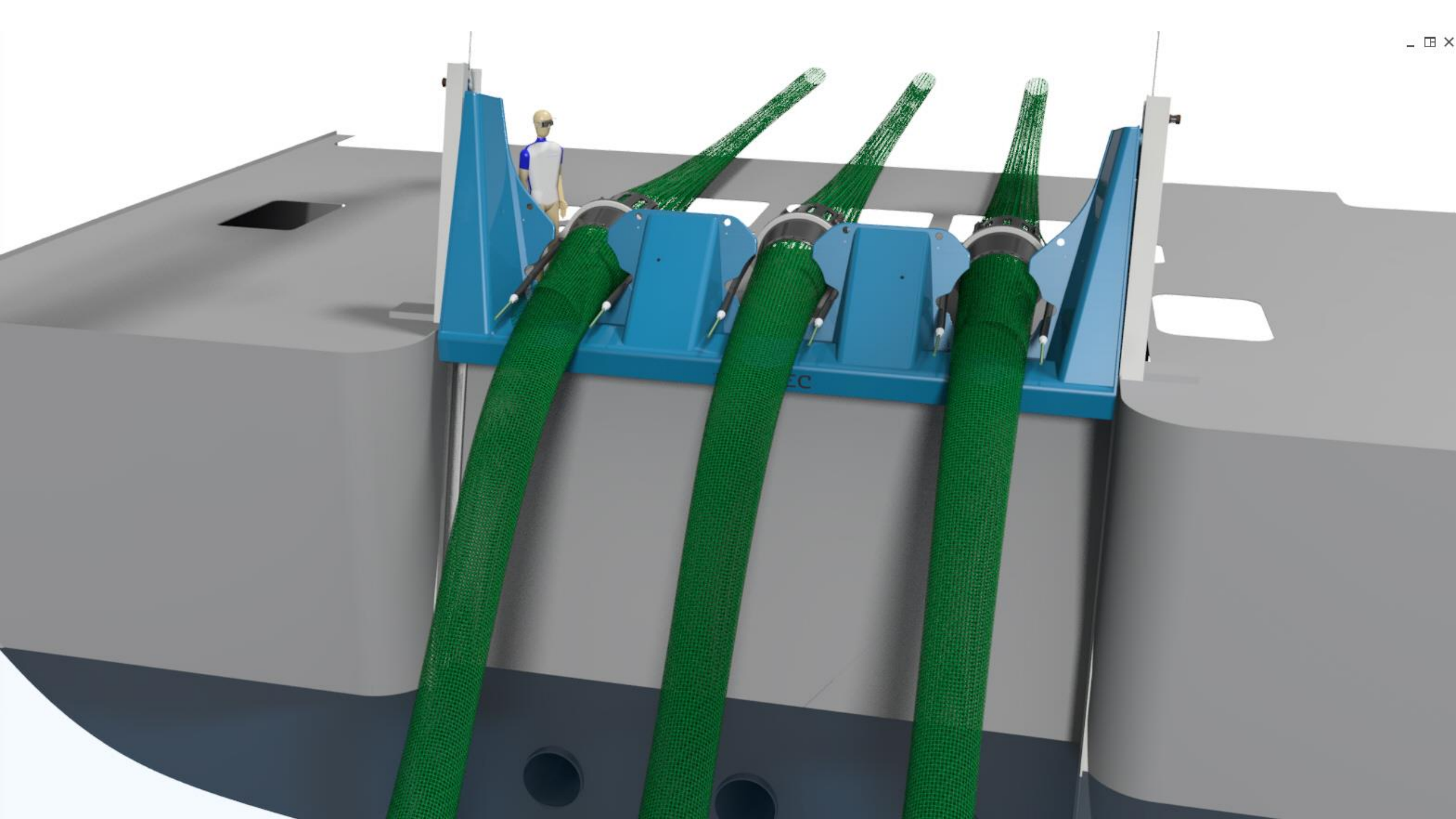

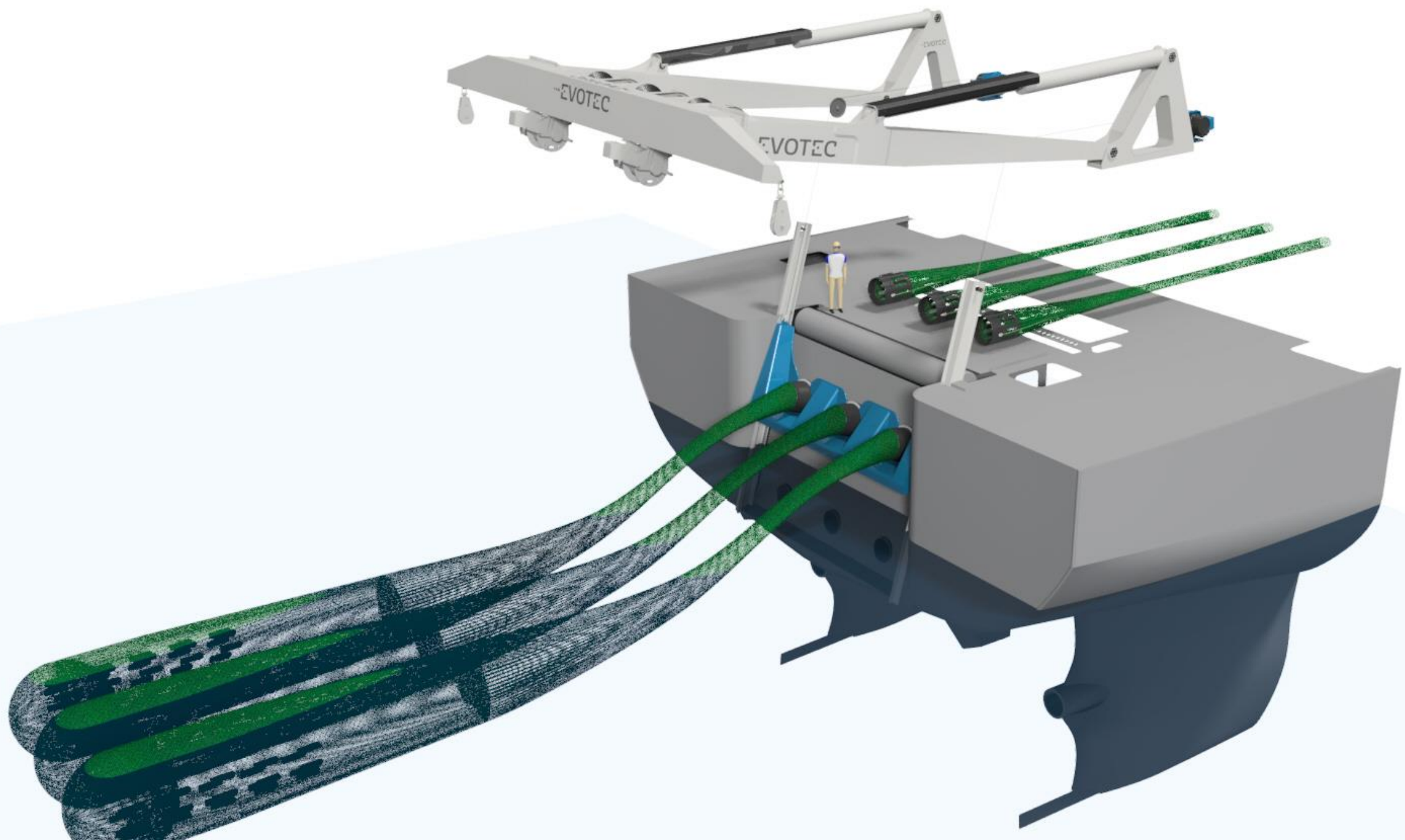

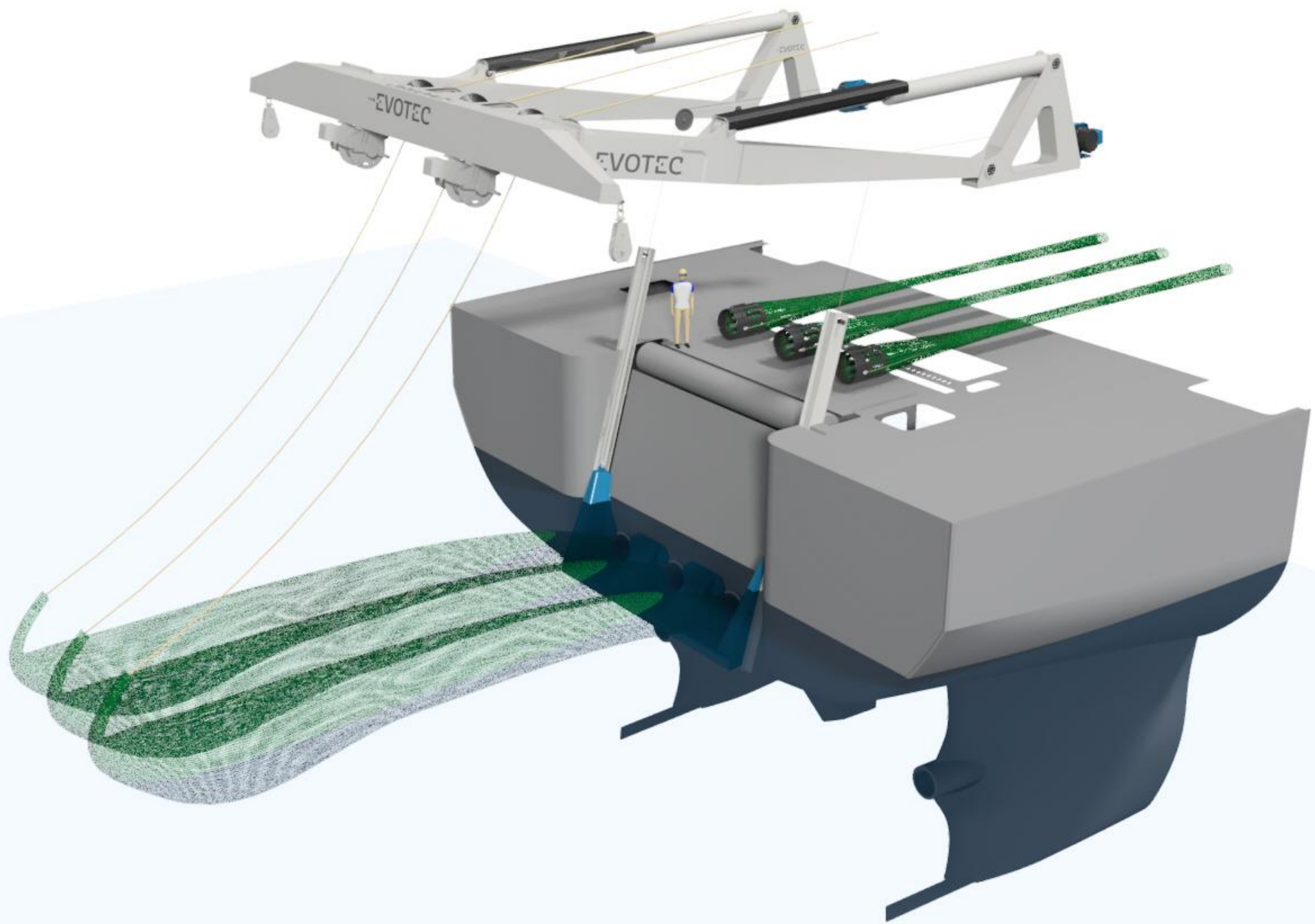

Leads the fish into a water-filled catch reception

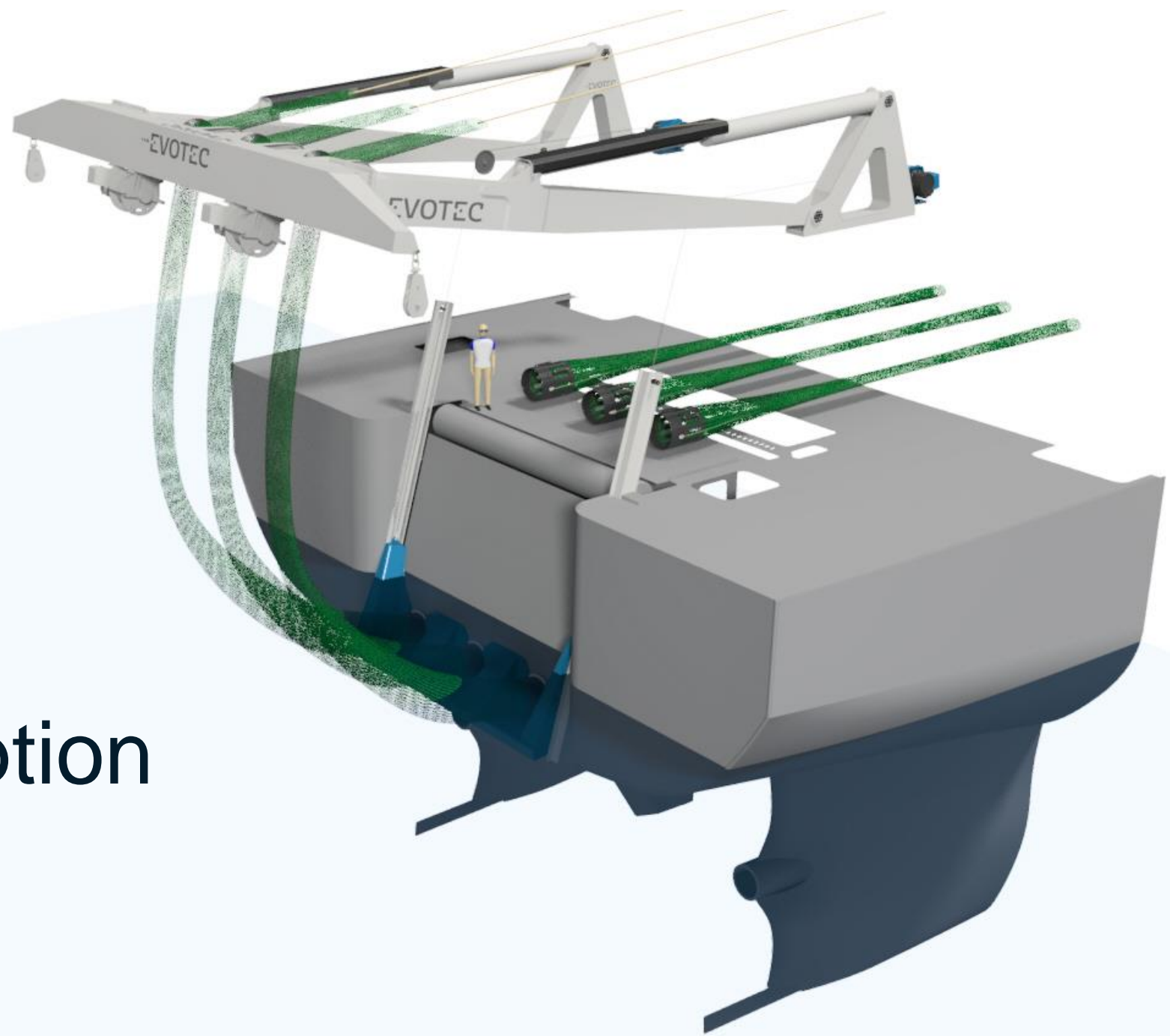

On-board processing

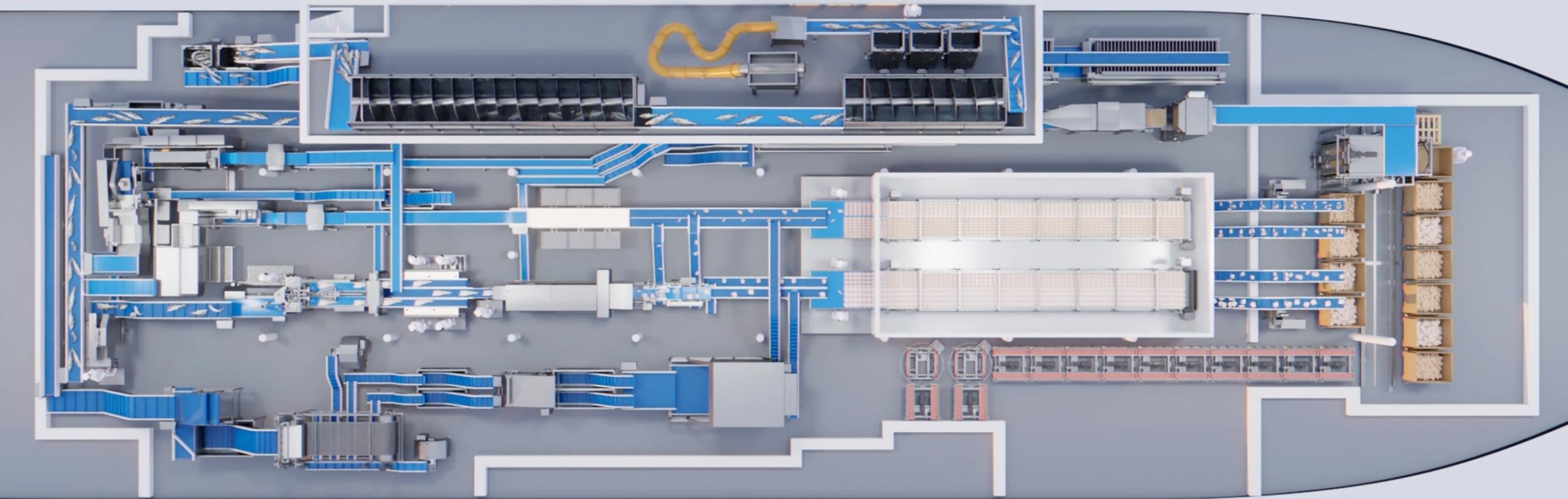

Aiming 100 % quality and 100 % utilisation

Vision grader

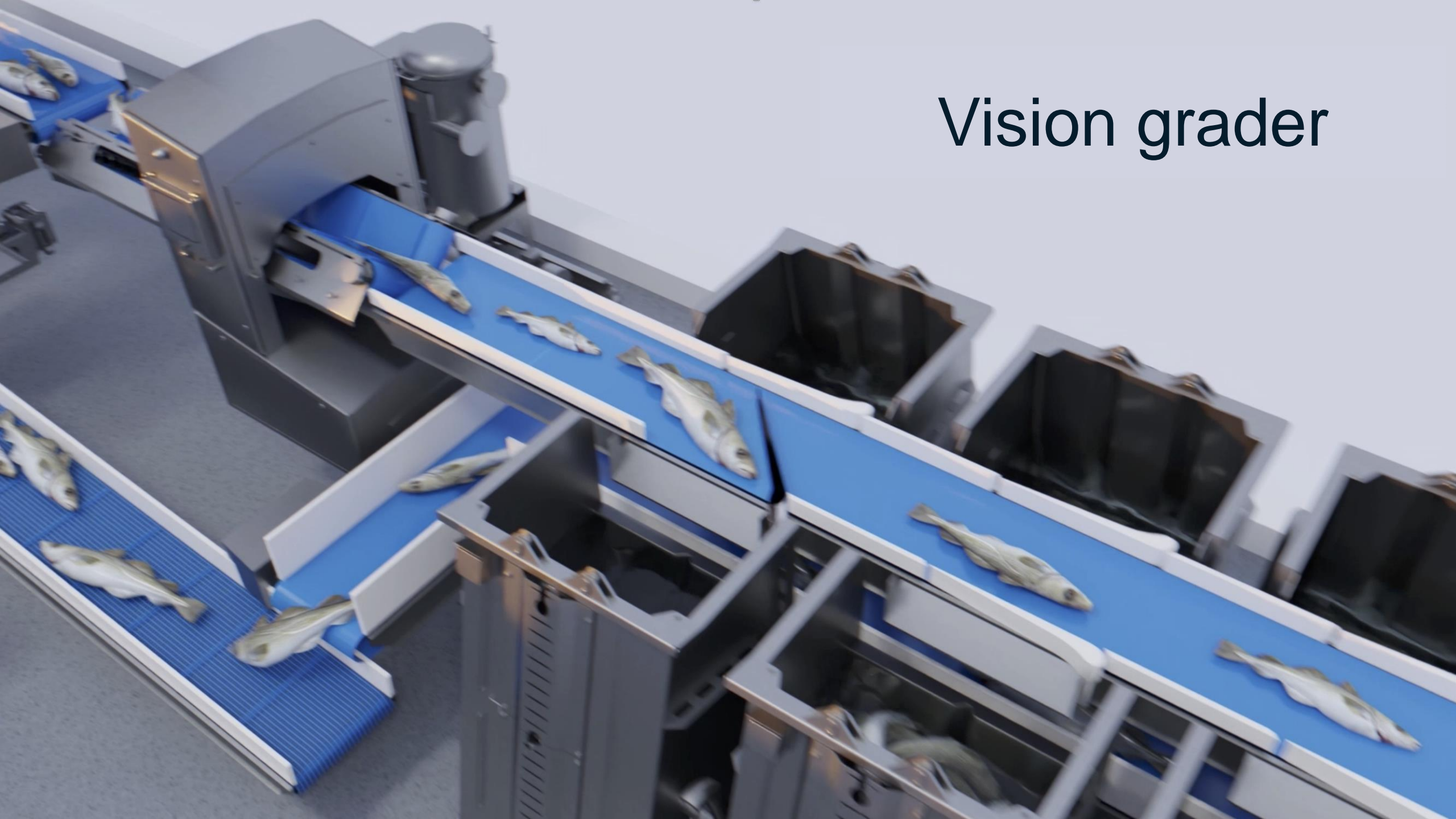

Filleting machine

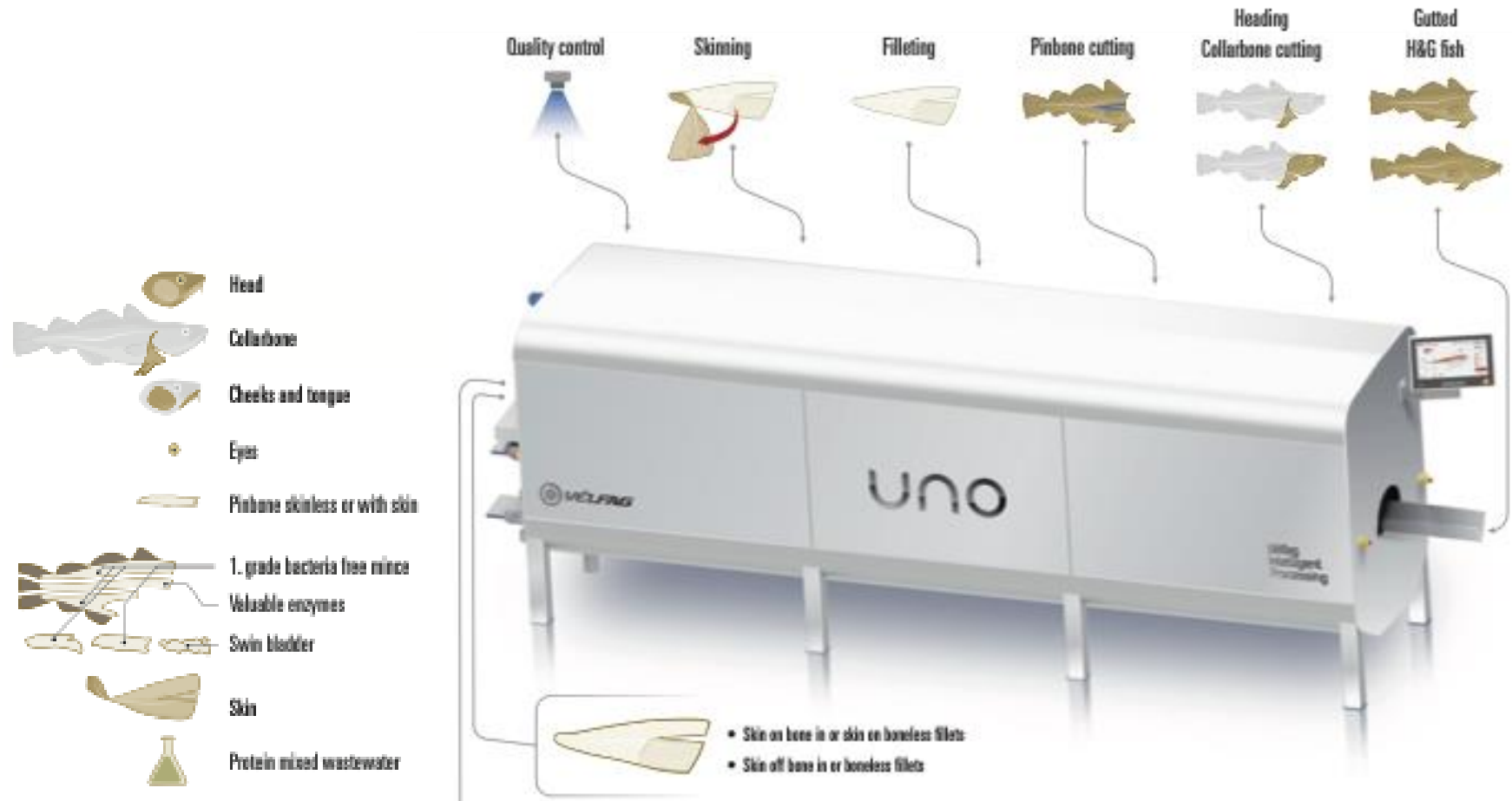

Palletizing

SKAGINN 3X

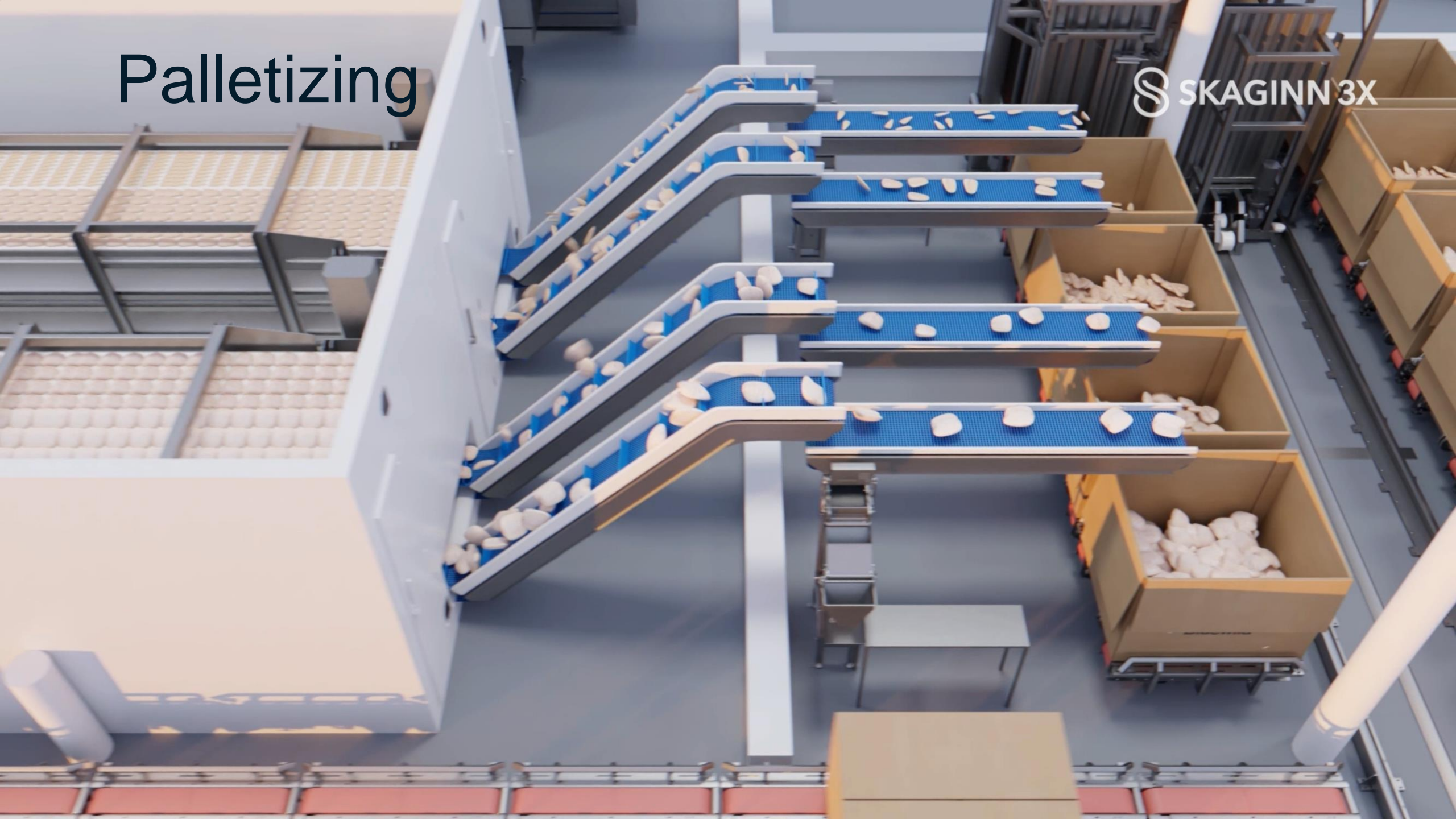

External data capture

A-FRAME
CAMERA
Visual
inspection of
the catch

WEATHER
STATION
Wind and
temperature

SATELLITE
Position and
speed

TRAWL
SENSORS

ECHO
SOUNDER
Fish
localisation
and seabed
structure

CURRENT
INDICATOR



Internal data capture



LIVE FISH
TANKS
CAMERAS
Visual
inspection

VISION
GRADER
Species,
size and
weight

FILETTING-
MACHINE

PORTION
CUTTER

PALLETIZER
WEIGHT

AUTO
STORE
SYSTEM

Information receivers

- Government
- On-board
- Head office
- Partners
- Consumer

Information goal: Full documentation – total transparency



Bluewild[®]

- Natural Seafood